

# SP28-SM31LR10x

## SFP28 25Gb/s 1310nm 10km Transceiver

### PRODUCT FEATURES

- Up to 25.78Gbps
- 10km transmission on SMF
- DFB Laser and PIN-TIA receiver
- Build-in dual CDR, for lower EMI
- 2-wire interface with integrated DDM
- Hot-pluggable SFP28 footprint
- Compliant with SFF 8472 and SFF-8402
- Single 3.3V power supply
- Power dissipation < 1.2W
- Case operating temperature:

Commercial: 0°C to +70°C

Extended: -10°C to +85°C

Industrial: -40°C to +85°C



### APPLICATIONS

- 25GBASE-LR
- eCPRI and CPRI

### PRODUCT DESCRIPTION

The SP28-SM31LR10x is SFP28 module for duplex optical data communications support 25.78 Gb/s and 28.05 Gb/s data links. It is with the SFP+ 20-pin connector to allow hot plug capability. Digital diagnostic functions are available via an I2C. It has built-in dual clock and data recovery (CDR). This module is designed for single-mode fiber and operates at a nominal wavelength of 1310nm. The transmitter section uses a high performance 1310nm DFB laser and is a class 1 laser compliant according to International Safety Standard IEC-60825. The receiver section uses an integrated InGaAs detector pre-amplifier (IDP) mounted in an optical header and a limiting post-amplifier IC.

## Ordering information

Product part Number	Data Rate (Gbps)	Media	Wavelength (nm)	Transmission Distance(km)	Temperature Range ( Tcase ) ( °C )	
SP28-SM31LR10C	25.78	Single mode fiber	1310	10	0~70	Commercial
SP28-SM31LR10I	25.78	Single mode fiber	1310	10	-40~85	Industrial
SP28-SM31LR10E	25.78	Single mode fiber	1310	10	-10~85	Extended

## Absolute Maximum Ratings

Parameter	Symbol	Min.	Typ.	Max.	Unit	Note
Storage Temperature	T <sub>s</sub>	-40	-	85	°C	
Relative Humidity	R <sub>H</sub>	5	-	95	%	
Power Supply Voltage	V <sub>CC</sub>	-0.3	-	4	V	
Signal Input Voltage	V <sub>SI</sub>	V <sub>CC</sub> -0.3	-	V <sub>CC</sub> +0.3	V	
Rx Damage Threshold	PR <sub>dmg</sub>	3			dBm	

## Recommended Operating Conditions

Parameter	Symbol	Min.	Typ.	Max.	Unit	Note	
Case Operating Temperature	Tcase	0	-	70	°C	SP28-SM31LR10C	
		-10		85	°C	SP28-SM31LR10E	
		-40		85	°C	SP28-SM31LR10I	
Power Supply Voltage	V <sub>CC</sub>	3.14	3.3	3.47	V		
Power Supply Current	I <sub>CC</sub>	-		363	mA		
Data Rate	BR		25.78		Gbps		
Transmission Distance	TD			10	km		
Coupled fiber	Single mode fiber						9/125um SMF

## Optical Characteristics

Parameter	Symbol	Min.	Typ.	Max.	Unit	Note
<b>Transmitter</b>						
Average Launched Power	P <sub>O</sub>	-5.0		+2.0	dBm	
Average Launched Power(Laser Off)	P <sub>off</sub>	-	-	-30	dBm	
Center Wavelength Range	λ <sub>C</sub>	1295	1310	1325	nm	
Spectrum Bandwidth(-20dB)	Δλ	-	-	1	nm	

Side-Mode Suppression Ratio	SMSR	30	-	-	dB	
Transmitter and Dispersion Penalty	TDP			2.7	dB	
Extinction Ratio	ER	3.5		-	dB	Note (1)
<b>Receiver</b>						
Input Optical Wavelength	$\lambda_{IN}$	1270	-	1610	nm	
Receiver Sensitivity (Average power)	$P_{sen}$	-	-	-13.3	dBm	Note (3)
Input Saturation Power (Overload)	$P_{SAT}$	2.0	-	-	dBm	Note (3)
Los Of Signal Assert	$P_A$	-30	-	-	dBm	
Los Of Signal De-assert	$P_D$	-	-	-16	dBm	
LOS -Hysteresis	$P_{Hys}$	0.5		5	dB	
Output Eye Mask	Compliant with IEEE 802.3cc					Note (2)

Note:

Note (1): Measured with a PRBS  $2^{31}-1$  test pattern, @25.78Gb/s.

Note (2): Transmitter eye mask definition, Compliant with IEEE 802.3cc.

Note (3): Measured with Light source 1310nm, ER=3.5dB; BER  $\leq 5 \times 10^{-5}$  @PRBS= $2^{31}-1$  NRZ.

## Electrical Interface Characteristics

Parameter	Symbol	Min.	Typ.	Max.	Unit	Note
<b>Transmitter</b>						
Transmitter Fault Output-High	$V_{FaultH}$	2	-	$V_{CC}+0.3$	V	
Transmitter Fault Output-Low	$V_{FaultL}$	0	-	0.8	V	
Transmitter Disable Voltage- High	$V_{DisH}$	2	-	$V_{CC}+0.3$	V	
Transmitter Disable Voltage- low	$V_{DisL}$	0	-	0.8	V	
<b>Receiver</b>						
LOS Output Voltage-High	$V_{LOSH}$	2	-	$V_{CC}+0.3$	V	
LOS Output Voltage-Low	$V_{LOSL}$	0	-	0.8	V	

## Pin Description

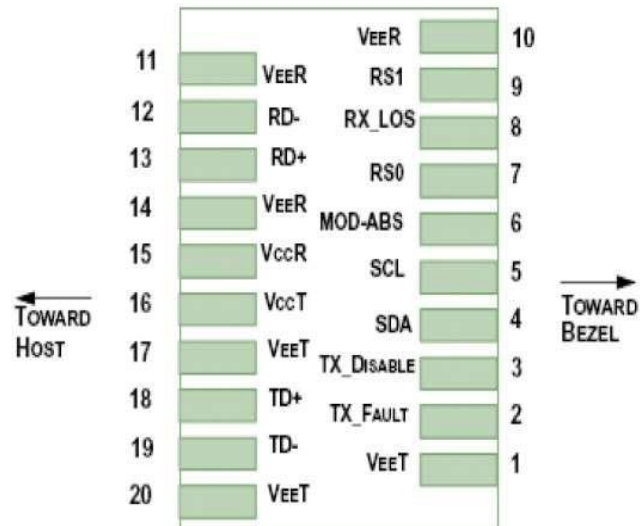

Diagram of Host Board Connector Block Pin Numbers and Name

Pin	Symbol	Name/Description	NOTE
1	$V_{EET}$	Transmitter Ground (Common with Receiver Ground)	1
2	$T_{FAULT}$	Transmitter Fault.	2
3	$T_{DIS}$	Transmitter Disable. Laser output disabled on high or open.	3
4	SDA	2-wire Serial Interface Data Line	4
5	SCL	2-wire Serial Interface Clock Line	4
6	MOD_ABS	Module Absent. Grounded within the module	4
7	RS0	Rate Select 0, internal pull down	5

Pin	Symbol	Name/Description	NOTE
8	LOS	Loss of Signal indication. Logic 0 indicates normal operation.	6
9	RS1	Rate Select 1, internal pull down	5
10	V <sub>EER</sub>	Receiver Ground (Common with Transmitter Ground)	1
11	V <sub>EER</sub>	Receiver Ground (Common with Transmitter Ground)	1
12	RD-	Receiver Inverted DATA out. AC Coupled	
13	RD+	Receiver Non-inverted DATA out. AC Coupled	
14	V <sub>EER</sub>	Receiver Ground (Common with Transmitter Ground)	1
15	V <sub>CCR</sub>	Receiver Power Supply	
16	V <sub>CCT</sub>	Transmitter Power Supply	
17	V <sub>EET</sub>	Transmitter Ground (Common with Receiver Ground)	1
18	TD+	Transmitter Non-Inverted DATA in. AC Coupled.	
19	TD-	Transmitter Inverted DATA in. AC Coupled.	
20	V <sub>EET</sub>	Transmitter Ground (Common with Receiver Ground)	1

**Notes:**

1. Circuit ground is internally isolated from chassis ground.
2. T<sub>FAULT</sub> is an open collector/drain output, which should be pulled up with a 4.7k – 10k Ohms resistor on the host board if intended for use. Pull up voltage should be between 2.0V to V<sub>cc</sub> + 0.3V. A high output indicates a transmitter fault caused by either the TX bias current or the TX output power exceeding the preset alarm thresholds. A low output indicates normal operation. In the low state, the output is pulled to <0.8V.
3. Laser output disabled on T<sub>DIS</sub>>2.0V or open, enabled on T<sub>DIS</sub><0.8V.
4. Should be pulled up with 4.7kΩ- 10kΩ host board to a voltage between 2.0V and 3.6V. MOD\_ABS pulls line low to indicate module is plugged in.
5. Rate select can also be set through the 2-wire bus in accordance with SFF-8472. Rx Rate Select is set at Bit 3, Byte 110, Address A2h. Tx Rate Select is set at Bit 3, Byte 118, Address A2h.
6. LOS is open collector output. It should be pulled up with 4.7kΩ – 10kΩ on host board to a voltage between 2.0V and 3.6V. Logic 0 indicates normal operation; logic 1 indicates loss of signal.

## Digital Diagnostic Monitor Accuracy

The following characteristics are defined over recommended operating conditions

Parameter	Accuracy	Unit
Internally measured transceiver temperature	+/-3	deg.C
Internally measured transceiver supply voltage	+/-3	%
Measured Tx bias current	+/-10	%
Measured Tx output power	+/-3	dB
Measured Rx received average optical power	+/-3	dB

## Recommended Interface Circuit

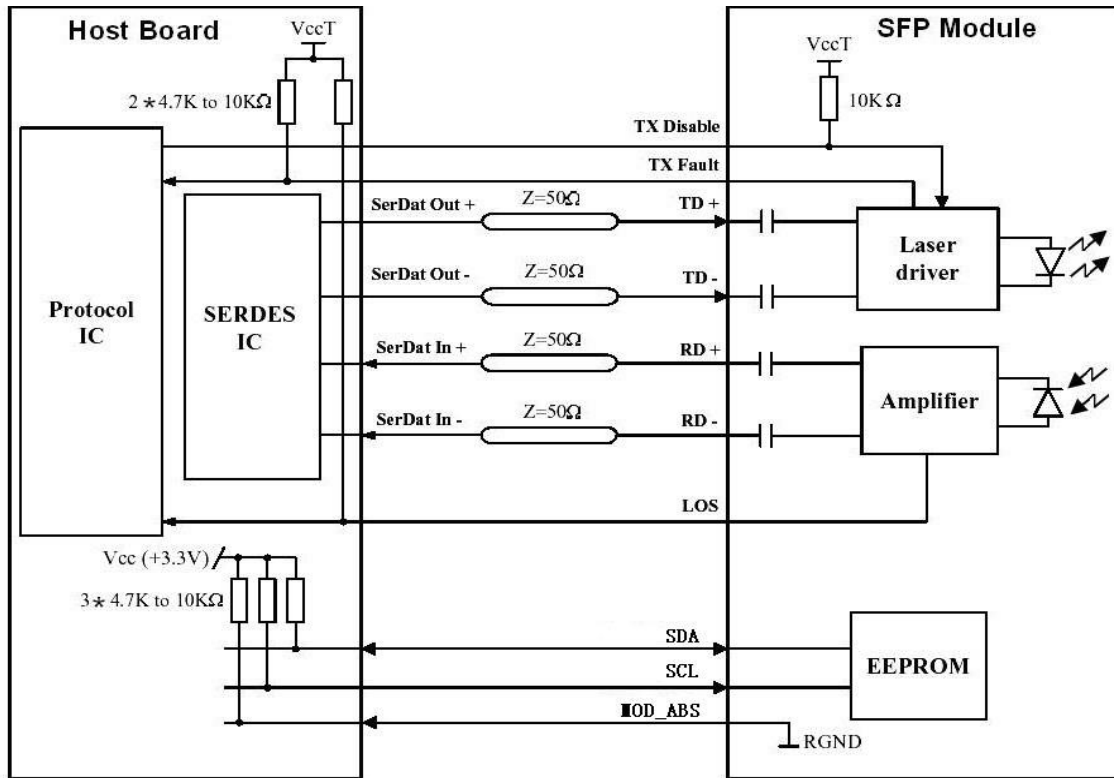

## Recommended Filter for Voltage Supply

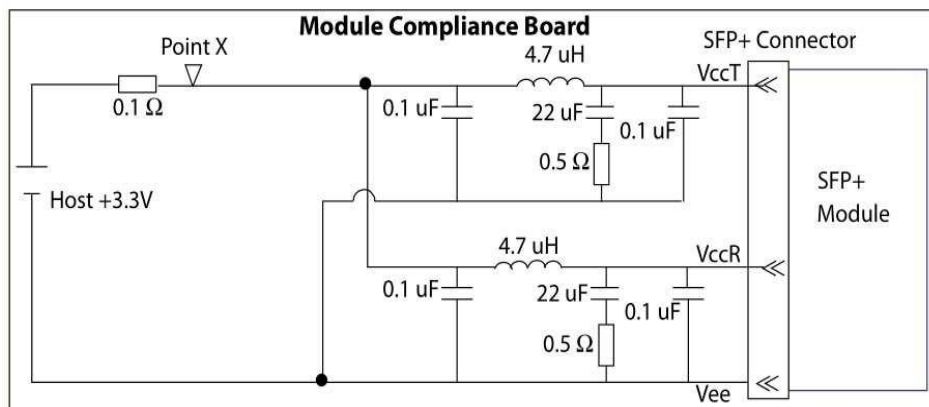

## Mechanical Dimensions

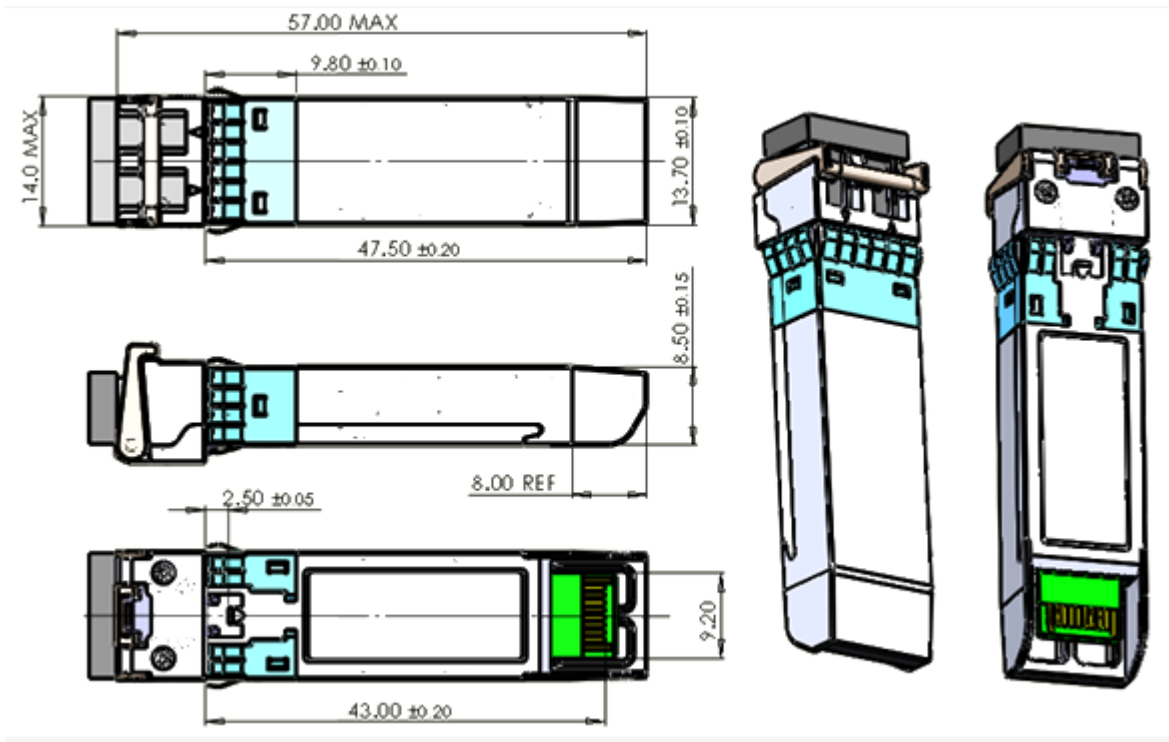

## Regulatory Compliance

Feature	Reference	Performance
Electrostatic discharge (ESD)	IEC/EN 61000-4-2	Compatible with standards
Electromagnetic Interference (EMI)	FCC Part 15 Class B EN 55022 Class B (CISPR 22A)	Compatible with standards
Laser Eye Safety	IEC/EN 60825-1, 2	Class 1 laser product
Component Recognition	IEC/EN 60950, UL	Compatible with standards
ROHS	2002/95/EC	Compatible with standards
EMC	EN61000-3	Compatible with standards